

Source: Volkswagen AG

**ARNOLD**<sup>®</sup>  
BlueFastening Systems



# Flexweld<sup>®</sup>

## Resistance element welding

### The market's demands

- + Multi-material mix
- + Security against loss of elements
- + Use of existing welding technology for a variety of joining tasks
- + Corrosion-resistance
- + No extra worker qualifications
- + Low susceptibility to tolerance fluctuations
- + Saving weight
- + Flexibility in materials
- + Suitability for high-volume production
- + Wide variety of metal thicknesses
- + Reducing cost of each joining point.
- + Using existing quality characteristics

ARNOLD provides the solution

## Flexweld<sup>®</sup>

### Resistance element welding



Watch how  
Flexweld<sup>®</sup> works

ARNOLD UMFORMTECHNIK provides an extensive selection of videos and animations. Just scan the QR code above or visit our website and click on our Youtube channel ARNOLD TV.

[www.arnold-fastening.com](http://www.arnold-fastening.com)

The considerable reduction in weight is one of the great strengths of the Flexweld® joining system. So it is a key element in moving car production towards more light-weight construction.

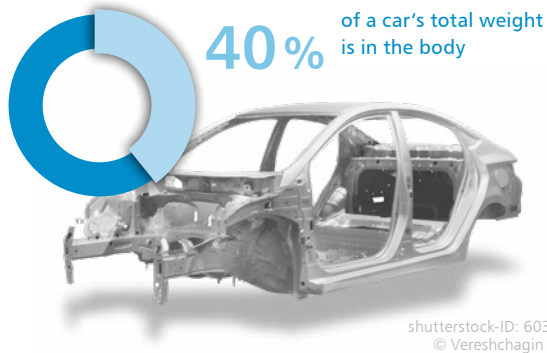

### Technical advantages of Flexweld®

- Joins maximum strength steels
- Hybrid materials combinations
- Uses elements with a variety of surfaces
- High level of flexibility regarding material and sheet thickness
- Uses standard equipment
- Security against loss of elements due to the splay on insertion
- Very good fastening performance
- Narrow flanges can be implemented

### Commercial advantages of Flexweld®

- Saves on investment costs because it uses existing production technology
- Makes more use of existing welding equipment (RoI) due to optimised composite production
- Less additional training and worker qualification
- Less additional training and worker qualification
- Lower cost for the customer by obtaining element and system from a single source „One Face to the Customer“

## Flexweld® The joining process in detail

Flexweld® elements are selfpunched and embedded into the aluminium sheet. This sheet is then welded to steel components, using conventional resistance spot welding guns, and then bonded with adhesive.

### Producing the subassembly pre-fabricated aluminium components

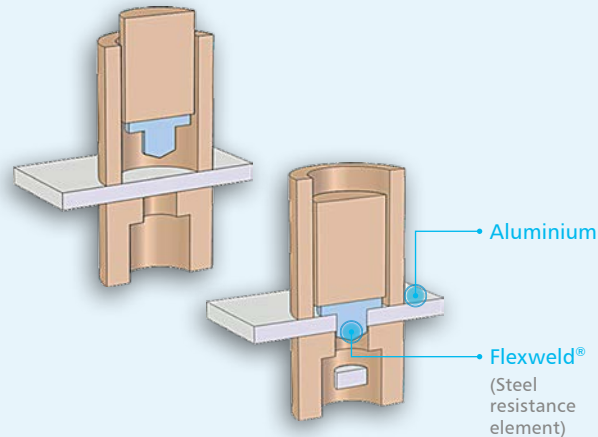

### Main body line Adhesive bonding and resistance welding

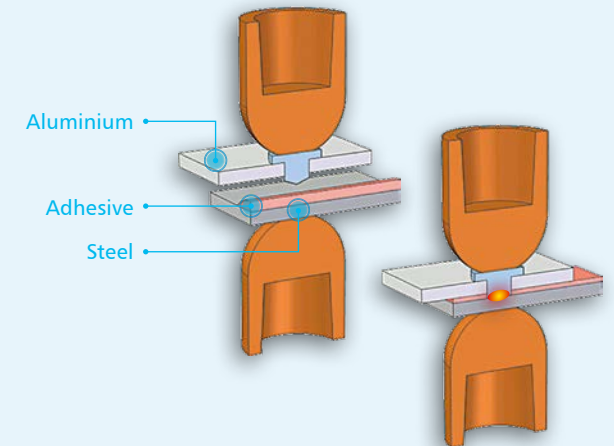

**Learn more**  
about Flexweld®, the unique  
resistance element welding  
technology.

[www.arnold-fastening.com](http://www.arnold-fastening.com)