

ThreadLoc[®]

Innovative chemical and
mechanical thread locks

- ⊕ Chemical and mechanical thread locks in use
- ⊕ Thread locks with sealing and damping function

➔ www.arnold-fastening.com



The topic of screw locks – more relevant than ever

The screw fastener has always represented one of the most important removable fasteners in practical use. Along with that, the matter of how to lock fasteners against accidental detachment is a well-known topic.



istock-ID: 537891253 | © vernonwiley

Everyone has experienced the annoyance this can cause at home - a loose screw in a pair of spectacles, or on a door handle. With the technical progress that has taken place in recent years, increasing numbers of safety-critical applications have been created at the highest level, in which the fasteners used are set the highest of requirements. In this respect, creating a reliable screw fastening requires a response to the question of what we need to do to ensure that the fastening does not work loose, or perhaps even detach completely. Because the result of these two conditions could have some devastating consequences.

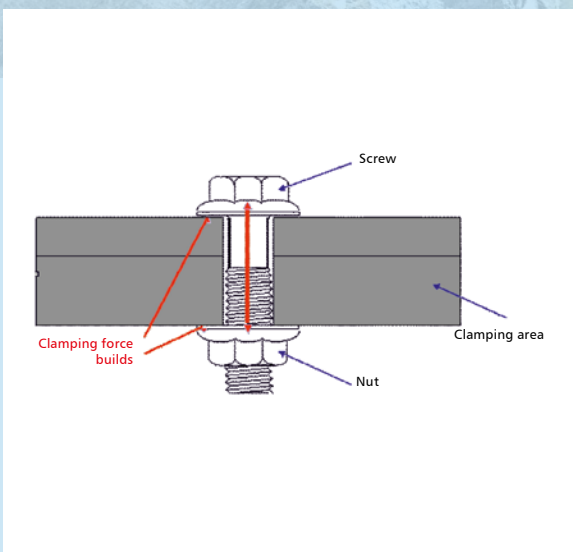

How does a screw fastening work?

To answer the question of how a screw fastening could actually fail, we need to look at the entire fastening system. By carrying out appropriate calculations and designing the fastening, as well as selecting the correct assembly process, sufficient clamping force will be applied within the fastening system to secure the screw. Under static operating conditions there is no need for a screw locking device because even under load there is sufficient clamping force to prevent the fastener from coming loose on its own.

Why do screw fasteners fail?

Practical experience shows that screw fasteners can fail by coming loose – in particular as a result of static and dynamic loads such as shaking or vibration.

We can distinguish between two different types of failure:

1. Failure due to loosening

Static or dynamic loads, particularly in an axial direction, allow stresses to form which in turn cause deformation characteristics and creepage. This reduces the residual clamping length and thus the fastening's pre-load force. In this situation an incorrectly designed clamping length ratio hugely increases the risk of failure of the screw fastening.

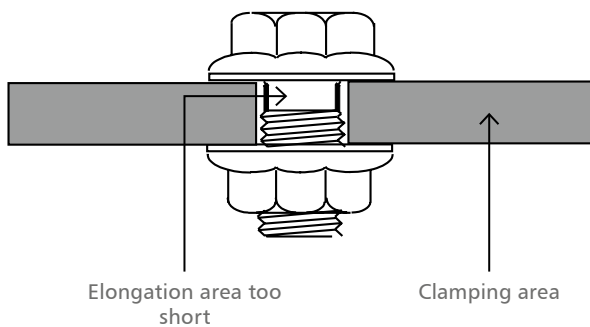

2. Failure due to unscrewing movements

A wide variety of dynamic loads - caused by anything from temperature variations to vibrations - presents the risk of the screw detaching by unscrewing itself. An insufficiently high pre-load force or badly contacting surfaces can cause relative movements, generating a loosening torque in the screw fastening, which causes the fastener to be completely lost.

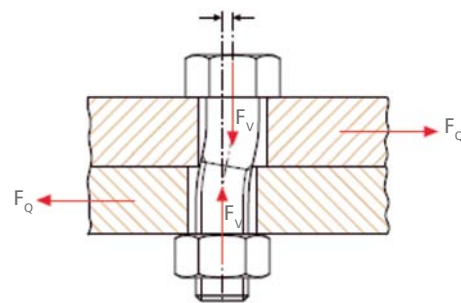

Conventional reactions to the risks of detachment and loosening

For many years engineers have used spring washers and lock washers to counter the risk of screw fasteners detaching or loosening. However, some time ago the Deutsche Institute für Normung (DIN) established that these are completely ineffective for locking a screw fastening. The use of commercially available toothed and serrated lock washers indicates the same characteristics. A correctly designed screw fastening creates a considerably higher pre-load force than these auxiliary devices can ever provide. So what should we do when static and dynamic loads make it necessary to protect fastenings against loosening, detaching, or even getting lost, and where, additionally, there are even more requirements with regard to the fastening's damping and sealing properties?



Spring rings and lock washers do not offer sufficient protection against a screw fastening coming loose or detaching.

ThreadLoc® – the comprehensive product range to meet every screw fastening need

In ThreadLoc® ARNOLD UMFORMTECHNIK has created a full product range to meet every screw fastening need. From the range, users are able to find the right fastening, damping or sealing solution to suit their particular application, and thus ensure constantly successful fastenings.

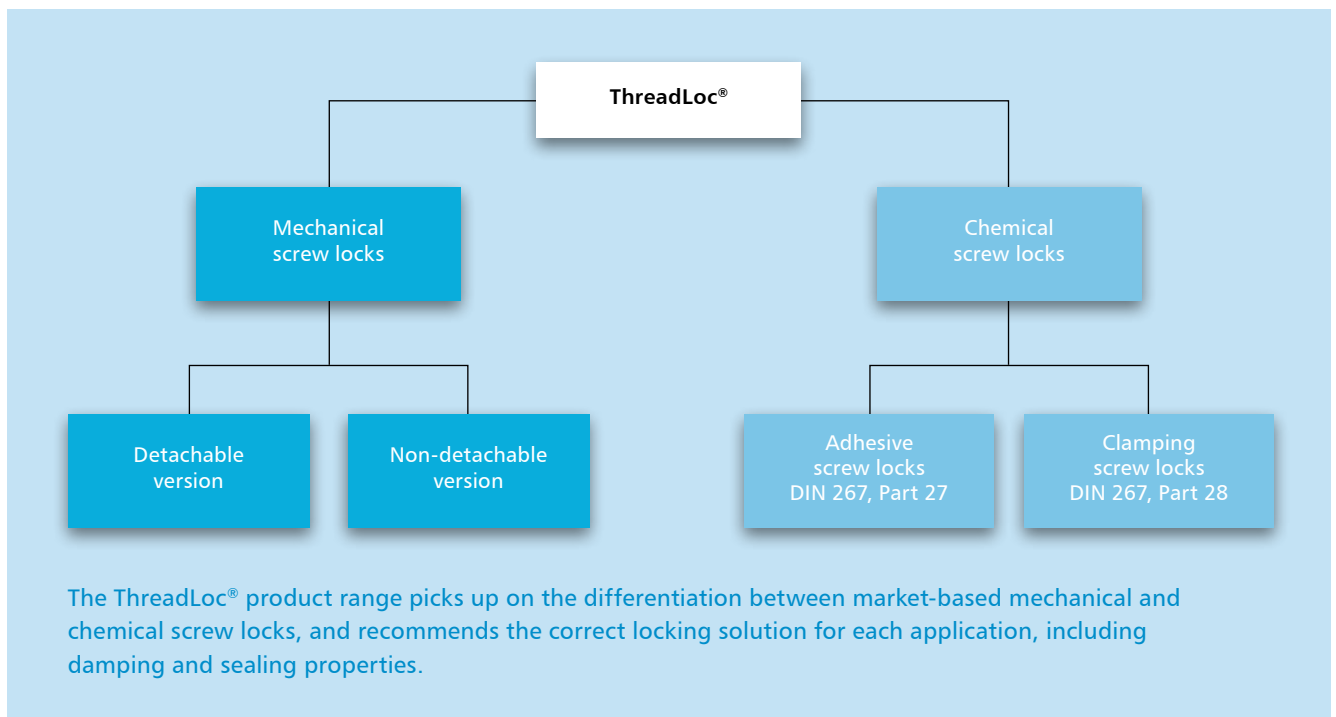

We make the distinction according to the following requirements:



Locking (general requirements)

Under dynamic loads, screw connections have a tendency to come loose by themselves. So the crucial factor in securing against vibration, corrosion, heat and screw deformation is therefore selecting the correct screw lock. ARNOLD's ThreadLoc® series provides a comprehensive range of mechanical and chemical locking systems for screw fastenings.



Sealing and damping (general requirements)

There are two versions available for sealing and damping screw fastenings. The first is the option of generating the sealing or damping function in the thread, and the second is generating it directly below the screw head. Both systems are thus directly integral to the assembly element and require no further measures.

The ThreadLoc[®] product range in detail

ThreadLoc[®] with adhesive

Complies with DIN 267 part 27
(chemically reactive)

- ⊕ Reliable locking against self-actuating detachment
- ⊕ Adhesive as well as sealing function
- ⊕ Dry, touch-proof locking coat ready for use at any time
- ⊕ Once cured, unaffected by oil and grease
- ⊕ Screw and fastener form a single unit and thus the locking element cannot detach
- ⊕ No extra stockholding required
- ⊕ Easy and secure assembly

Recommended products

- ⊕ Precote 30 yellow
- ⊕ Precote 85 turquoise
- ⊕ 3 M Scotch-Grip 2353 blue

ThreadLoc[®] with clamping

Complies with DIN 267 part 28
(not chemically reactive)

- ⊕ Reliable lock against a screw fastening detaching completely (counter effect to unscrewing rotation, however it cannot be arrested)
- ⊕ Simultaneous clamping and sealing function against fluids and gases (with all-round coating)
- ⊕ Dry, touch-proof locking coat ready for use at any time
- ⊕ Resistant to almost all aggressive media
- ⊕ Screw and fastener form a single unit, no need for mechanical locking elements, no dual stockholding required, no additional assembly work, impossible to forget the locking element, non-detachable
- ⊕ Easy and secure assembly
- ⊕ Load can be applied immediately after assembly

Recommended products

- ⊕ Tuflok Fleck / all-round product
- ⊕ Polyamid Fleck / all-round product

Receipt of preload with constant dynamic stress crossways to axis

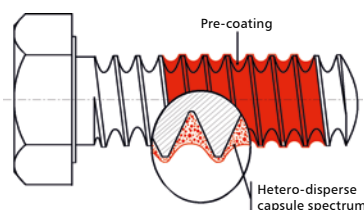
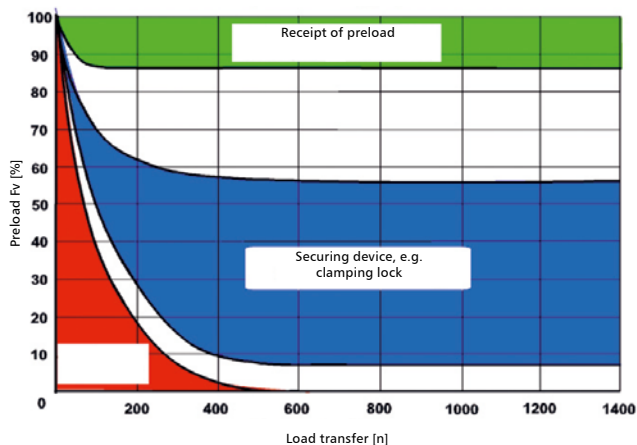

The ThreadLoc® product range in detail

Sealing and damping (in the thread)

Thread seals and dampers are dry or touch-proof, dry-on coatings which fill the thread gap, but which produce no chemical reaction, and are thus 100% ready for use after application

- + Good sealing and damping properties
- + Resistant to aggressive media
- + Ready coated

Recommended products

- + Precote 5 white
- + Precote 15
- + GESI seal white



Sealing and damping (beneath the head)

Below-head sealing and damping systems in polyamide or polyolefin are produced either by fusing the plastic directly onto the underside of the screw heads, or by applying a nylon ring, which is then fused onto the underside of the screw head.

- + Good sealing and damping properties
- + Can be used many times
- + Effective against contact corrosion
- + Low wear, suitable for automated assembly

Recommended products

- + GESI Plastisol black
- + Precote 200
- + Plastisol holder ring



ThreadLoc[®] – detachable mechanical screw lock

Recommended product:

- ➕ POWERLOK[®] locking screws



Figure 1

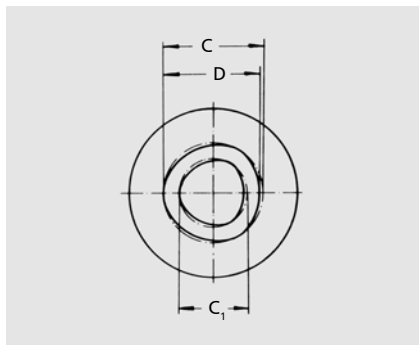
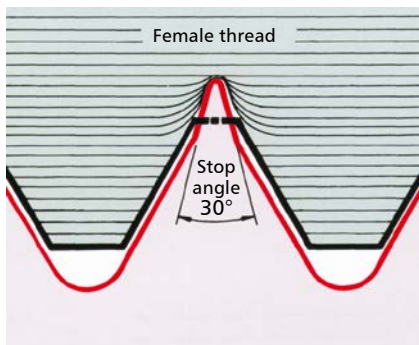

Figure 2

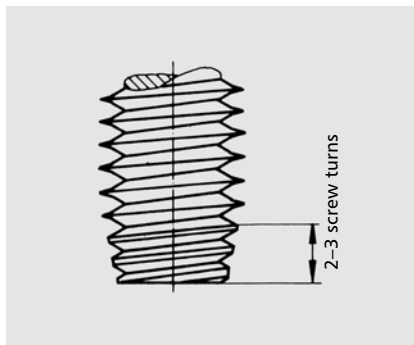

Figure 3

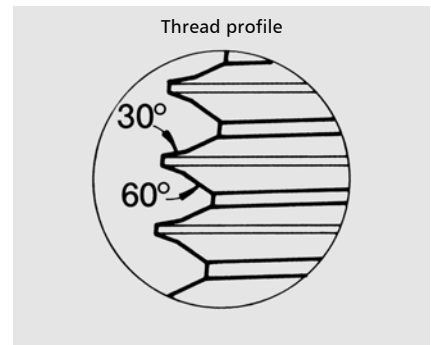

Figure 4

POWERLOK[®] screws are locking screws with a TRILOBULAREM[®] screw thread. They screw into an existing metric ISO thread (tolerance range 6H). Small 30° edges are rolled on the regular 60° thread edges, and these extend beyond the nominal bolt thread diameter. When the fastener is screwed into the counter-thread (ISO 6H), these 30° tips penetrate and cause the screw to self-lock, thus creating an oscillation and vibration-resistant seat.

The deformation of the female thread caused by the 30° tips takes place in the flexible area. This ensures a high degree of self-locking and a reusability rate for the screw of up to five times into the same female thread. There is no possibility of lengthways or crossways movement between screw and female thread. Even in ductile materials, no signs of deformation occur. Even without head friction, the ARNOLD POWERLOK[®] thread guarantees a high degree of vibration resistance – a benefit when used as threaded bolt or setting screw.

POWERLOK® – firm fastening against oscillation and vibration

Screw dimension

POWERLOK® screws comply with quality class 10.9.
 POWERLOK® screws are a fastening and locking device in one.
 They replace mechanical and chemical screw lock devices.

- ⊕ Smooth, fully-automated assembly can be achieved because there are no malfunctions caused by rolled on fasteners getting hooked up.
- ⊕ The locking effect is not affected by temperature or ageing (as is often the case with chemical locking methods).
- ⊕ Feeder malfunctions, caused by friction on plastic parts in vibrating feeders, cannot occur.

Sure and firm fastenings with POWERLOK® screws. They are the right solution for oscillating and vibrating environments!

Nominal diameter	Screw dimension					Nominal lengths
	C		D		C ₁	
	min.	max.	min.	max.	min.	
M3	3.06	3.16	2.96	3.06	2.98	5–25
M3.5	3.57	3.67	3.45	3.55	3.48	6–25
M4	4.08	4.23	3.94	4.09	3.98	8–30
M5	5.11	5.26	4.95	5.10	4.98	8–35
M6	6.15	6.30	5.95	6.10	5.98	10–50
M8	8.20	8.35	7.95	8.10	7.97	12–80

Table 1

Head versions to all DIN shapes, including with TORX® (special head shapes on request)

Comparison of screw-in and unscrew operations POWERLOK[®] — chemical screw locks

ARNOLD-POWERLOK[®]

M5 × 12
Steel 8.8
Screw-in depth 7.5 mm
(1.5 × d)
MA 5.7 Nm

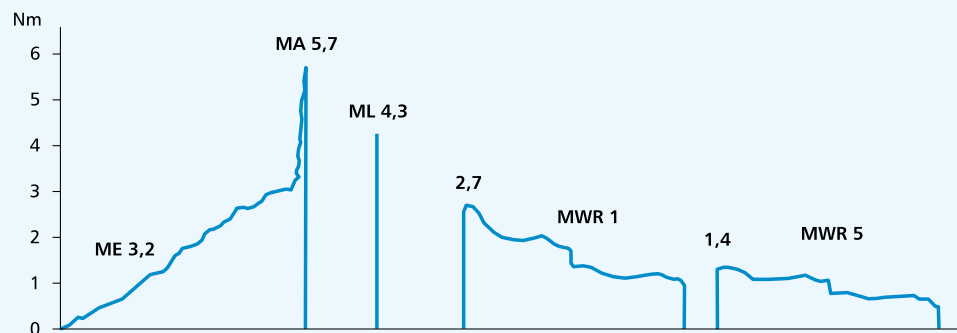

Figure 5

Chemical screw lock

M5 × 12
Steel 8.8
Screw-in depth 7.5 mm
(1.5 × d)
MA 5.7 Nm

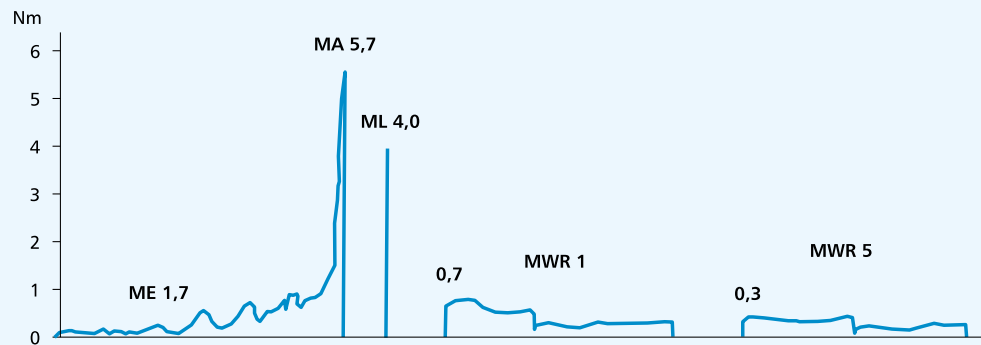

Figure 6

The ARNOLD GROUP

Wherever customers need us.

The ARNOLD GROUP

ARNOLD – this name is internationally renowned for efficient and sustainable fastening systems on the highest level. With a foundation of many years of expertise in the production of intelligent fastening systems and very complex extruded parts, the ARNOLD GROUP has developed over a number of years into a comprehensive supplier and development partner for complex fastening systems. With our positioning of “BlueFastening Systems” this development process will continue under a united and harmonized structure. Engineering, fasteners, and functional parts, together with feeding and processing systems, all from a single source – efficient, sustainable and international.



**ARNOLD
FASTENING SYSTEMS**
Rochester Hills
USA



ARNOLD UMFORMTECHNIK
Ernsbach
Germany



ARNOLD UMFORMTECHNIK
Dörzbach
Germany



**ARNOLD
FASTENERS SHENYANG**
Shenyang
China

**ARNOLD FASTENING
SYSTEMS Inc.**

1873 Rochester Industrial Ct.,
Rochester Hills, MI 48309-3336
USA
T +1 248 997-2000
F +1 248 475-9470

**ARNOLD UMFORMTECHNIK
GmbH & Co. KG**

Carl-Arnold-Straße 25
74670 Forchtenberg-Ernsbach
Germany
T +49 7947 821-0
F +49 7947 821-111

**ARNOLD UMFORMTECHNIK
GmbH & Co. KG**

Max-Planck-Straße 19
74677 Dörzbach
Germany
T +49 7947 821-0
F +49 7947 821-111

**ARNOLD FASTENERS
(SHENYANG) Co., Ltd.**

No. 119-2 Jianshe Road
110122 Shenyang
China
T +86 24887 90633
F +86 24887 90999